

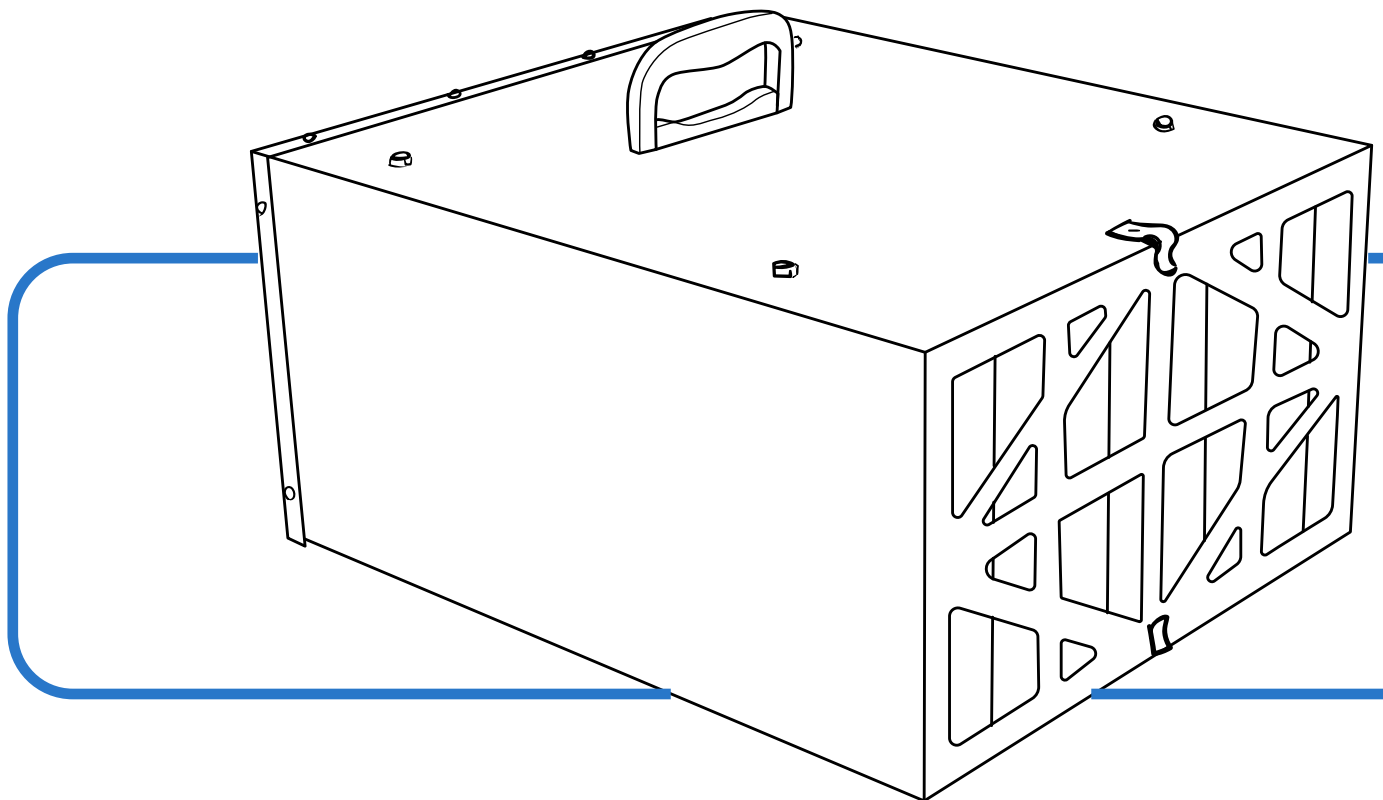

Air-Safti

AIR SCRUBBER

OWNERS MANUAL



Questions? Visit www.biocidelabs.com
or call us at (678) 971-4388.

You will need this manual for safety instructions, operating procedures, and warranty. Keep it and the original sales invoice in a safe, dry place for future reference.

BIO·CIDE
LABORATORIES

TABLE OF CONTENTS

Safety Rules	3
Assembly	5
Unpacking	
Installation	
Power Source	
Grounding Instructions	
Extension Cords	
Operations	9
ON/SPEED Control	
Filtration Timing	
To Turn the Unit OFF	
Maintenance	10
Changing the Filters	
Fuse Replacement	
Remote Control Battery Replacement	
Troubleshooting	11
Parts List	12
Warranty	13

PRODUCT SPECIFICATIONS

Horsepower (Max Developed) - 1/6HP
Voltage - 120V
Hertz - 60Hz
Controls - Manual or Remote
Number of Speeds - 3
Air Flow (CFM) - 300/350/400
Outer Filter - 5 Microns
Inner Filter - 1 Micron
Filtration Timing - Auto Off, 1 Hr, 2 Hr, 4 Hr
Impeller - Squirrel Cage
Sound Rating @ 3 Feet - High 69dB, Med
67dB, Low 62dB

MOTOR SPECIFICATIONS

This air filtration system is supplied with a 1/6HP motor installed. The 120 Volt AC universal motor has the following specifications:
Horsepower (Max Developed) - 1/6HP
Voltage - 120V
Hertz - 60Hz

GENERAL SAFETY RULES

WARNING

For your own safety, read and understand all warnings and operating instructions before using any tool or equipment.

WARNING

Some dust created by operation of power tool contains chemicals known to the State of California to cause birth defects or other reproductive harm. To reduce your exposure to these chemicals, work in a well ventilated area and work with approved safety equipment. Always wear OSHA/NIOSH approved, properly fitting face mask or respirator when using such tools.

WARNING

Failure to follow these rules may result in serious personal injury. Remember that being careless for even a fraction of a second can result in severe personal injury.

WORK PREPARATION

- Wear proper apparel. Do not wear loose clothing, gloves, neckties, rings, bracelets, or other jewelry which may get caught in moving parts of the tool.
- Nonslip protective footwear is recommended. Wear protective hair covering to contain long hair.
- Wear eye and hearing protection. Always use safety glasses. Eye protection equipment should comply with ANSI Z87.1 standards. Hearing equipment should comply with ANSI S3.19 standards.
- Wear face mask or dust mask if operation is dusty.
- Be alert and think clearly. Never operate power tools when tired, intoxicated or when taking medications that cause drowsiness.

WORK AREA PREPARATION

- Keep work area clean. Cluttered work areas and benches invite accidents.
- Work area should be properly lighted.
- Do not use the machine in a dangerous environment. The use of power tools in damp or wet locations or in rain can cause shock or electrocution.
- Three-prong plug should be plugged directly into properly grounded, three-prong receptacle.
- Use the proper extension cord. Make sure your extension cord is in good condition. It should have grounding prong and should be of the correct gauge.
- Keep children and visitors away. Your shop is a potentially dangerous environment. Children and visitors can be injured.
- Make your workshop childproof with padlocks, master switches, or remove switch keys to prevent any unintentional use of power tools.
- It should have a grounding prong and should be of the correct gauge.

TOOL MAINTENANCE

- Turn the machine "OFF," and disconnect the machine from the power source prior to inspection.
- Maintain all tools and machines in peak condition. Keep tools sharp and clean for best and safest performance.
- Follow instructions for lubricating and changing accessories.
- Check for damaged parts. Check for alignment of moving parts, binding, breakage, mounting, and any other condition that may affect tool's operation.
- Poorly maintained tools and machines can further damage the tool or machine and/or cause injury.
- A guard or any other part that is damaged should be repaired or replaced. Do not perform makeshift repairs.

GENERAL SAFETY RULES (cont.)

TOOL OPERATION

- Avoid accidental start-up. Make sure that the tool is in the “OFF” position before plugging in.
- Use the right tool for your job. Do not force your tool or attachment to do a job for which it was not designed.
- Disconnect tool when changing parts.
- Don't force the workpiece on the machine. Damage to the machine and/or injury may result.
- Never leave tool running unattended. Turn the power off and do not leave tool until it comes to a complete stop.
- Do not overreach. Loss of balance can make you fall into a working machine, causing injury.
- Never stand on tool. Injury could occur if the tool tips, or if you accidentally contact the cutting tool.
- Know your tool. Learn the tool's operation, application, and specific limitation before using it.
- Use a proper extension cord of the correct gauge. Your extension cord should have a grounding prong, and should be in good condition.
- Handle workpiece correctly. Keep hands away from moving parts.
- Turn tool off if it jams.
- Always feed workpiece against the direction of the sanding rotation. To maintain control, properly support long or wide work-pieces.

CAUTION

Think safety! Safety is a combination of operator common sense and alertness at all times when tool is being used.

WARNING

Do not attempt to operate tool until it is completely assembled according to the instructions.

**SAVE ALL WARNINGS AND INSTRUCTIONS FOR
FUTURE REFERENCE**

SPECIFIC SAFETY RULES FOR AIR SCRUBBER

Be aware of general power tool safety. Make sure all the safety rules are understood.

- Disconnect the machine from power source whenever adjusting or replacing any parts.
- Do not plug the air scrubber system in unless the switch is in the "OFF" position.
- Keep hands away from all moving parts.
- Wear eye protection or face shield during operation.
- Make sure all mobile parts move freely and are free from interference.
- If ceiling mounted, bottom of the air filtration system must be at least 7 feet above the floor.
- If ceiling mounted, mounts must be anchored to building structure which will support a minimum of at least 100 pounds. Never mount to surfaces such as drywall or false ceiling grinds, etc.
- To reduce the risk of electrical shock, do not expose the air scrubber to water or rain.
- Never duct a machine directly into the air filtration system.
- Do not use the air scrubber without filters in place.
- To avoid a potentially dangerous situation, do not use this machine to filter flammable vapors or smoke.
- Failure to follow these rules may result in serious personal injury or property damage.

ASSEMBLY

UNPACKING

Refer to Figure 1

The air scrubber is shipped assembled and requires minimum assembly and installation.

- Examine the shipping carton for freight damage before opening. If the shipping carton is damaged file a claim with the carrier immediately.
- Carefully remove all contents from the shipping carton. The shipping carton contains:
 - 1 Air Scrubber System
 - 1 Remote Control
 - 4 Mounting Hooks
 - 4 Eye Bolts
 - 4 Range Nuts
 - 4 Hook Chains
 - 1 Owner's Manual (not shown)

NOTE: Contact the customer service center if any of these parts are missing.

NOTE: After the unit is assembled dispose of all packaging material in an environmentally safe way.

INSTALLATION

Refer to Figure 1 to 4

The scrubber system is specifically designed to circulate and filter non-metallic dust, which is generated throughout the work area. The unit can be located on a workbench or hung from an overhead support. When selecting a location ensure the power source is easy to access. Use the carry handle when moving the unit.

IMPORTANT: When determining a location where the airflow is unrestricted. Locate the unit away from corners and any heating or cooling vents.

Figure 1

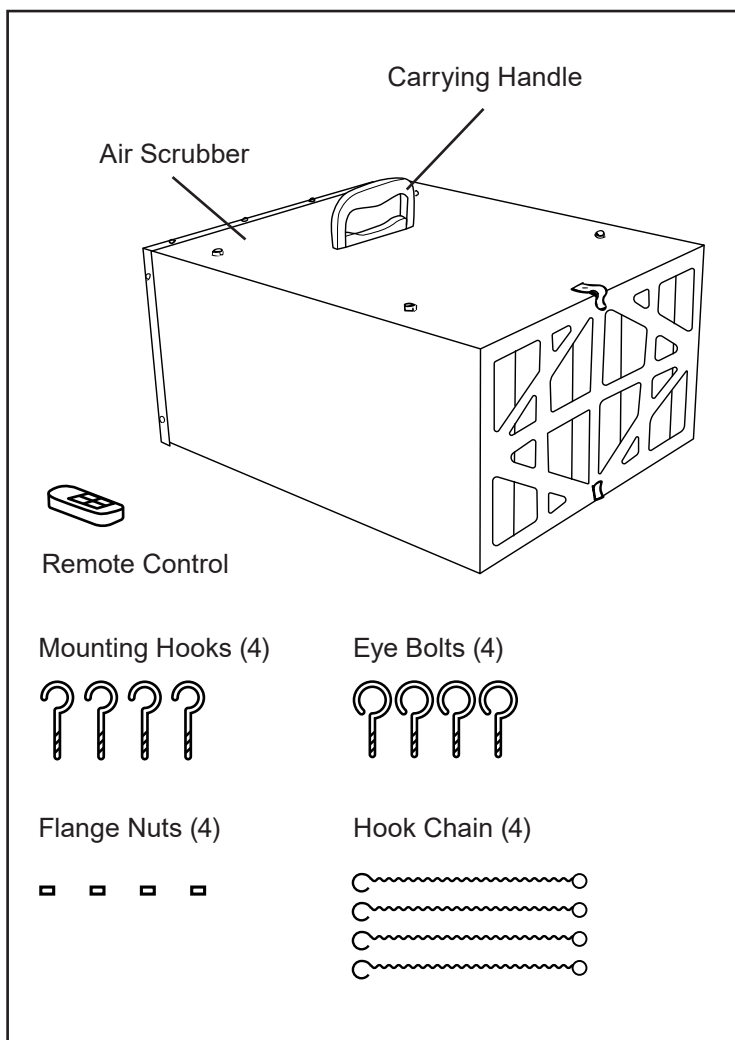

Work Bench Location

Place the air filtration system onto a workbench, ensure the airflow is not restricted and the unit is away from corners and any heating or cooling vents.

CAUTION

Clamp the air scrubber system in place if using on a workbench or sawhorses.

Hanging Mount

Tools required for assembly:

- No. 2 Phillips screwdriver (not supplied)
- 10mm wrench (not supplied)

NOTE: Hang the unit at least 7 feet above floor level and away from corners and heating or cooling vents.

- Remove four screws from the cabinet top (Figure 2).
- Thread the flange nut almost all the way up to the eye bolt (Figure 3).
- Thread the eye bolt into the hole on the cabinet top. Tighten the flange nut against the cabinet top. Hold the eye bolt so it does not spin while tightening the flange nut.
- Repeat for the remaining three eye bolts.
- Anchor the four mounting screws into the building's ceiling joist. Never mount to surfaces such as drywall or false ceiling grids, etc (Figure 4).

CAUTION

Mounting hooks must be anchored to a building structure that can support a minimum of 100 pounds. Never mount to surfaces such as drywall or false ceiling grids, etc.

- Place a hook chain on each mounting screw (Figure 4).
- Attach each eye bolt to the hook chain (Figure 4).
- Ensure the unit is level horizontally. Adjust if needed.
- Plug the power cord into the correct receptacle.

Figure 2

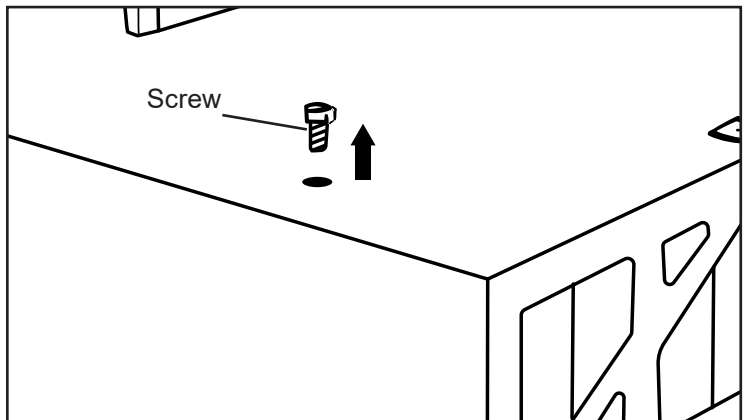

Figure 3

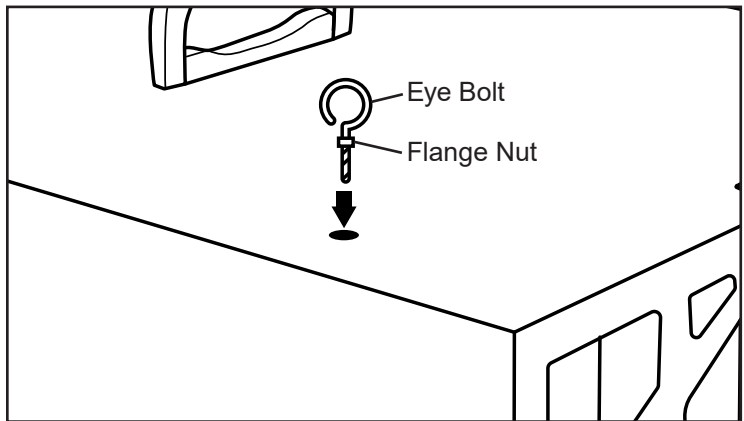
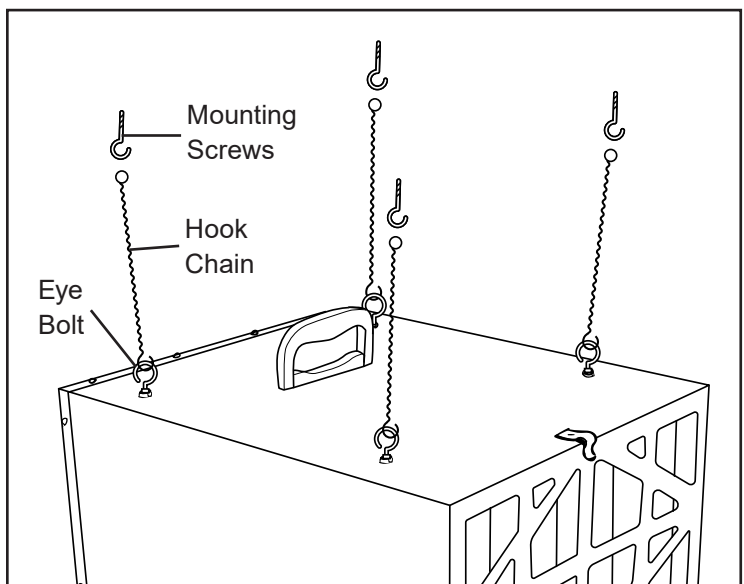

Figure 4



POWER SOURCE

WARNING

Do not connect to the power source until the machine is completely assembled.

The machine is wired for 120 volts, 60-hertz alternating current. Before connecting the machine to the power source, make sure the switch is in the "OFF" position. Running the unit on voltages that are not within range may cause overheating and motor burn-out. Heavy loads require that voltage at motor terminals be no less than the voltage specified on the nameplate.

GROUNDING INSTRUCTIONS

WARNING

Improper connection of equipment grounding conductor can result in the risk of electrical shock.

- The machine should be grounded while in use to protect the operator from electrical shock.
- In the event of an electrical short circuit, grounding reduces the risk of electrical shock by providing an escape wire for the electrical current.
- This machine is equipped with an approved 3-conductor cord rated at 120V and a 3-prong grounding-type plug for your protection against shock hazards.
- The grounding plug should be plugged directly into a properly installed and grounded 3-prong grounding-type receptacle, as shown (Figure 5).
- The plug must be plugged into an outlet that is properly installed and grounded in accordance with all local codes and ordinances.
- Check with a qualified electrician or service personnel if these instructions are not completely understood or if in doubt as to whether the tool is properly grounded.
- Do not modify the plug provided. If it will not fit in the outlet, have a proper outlet installed by a qualified electrician. Use only 3-wire extension cords, that have 3-prong grounding-type plugs and matching 3-conductor receptacles that accept the machine's plug, as shown in Figure 6.

Figure 5

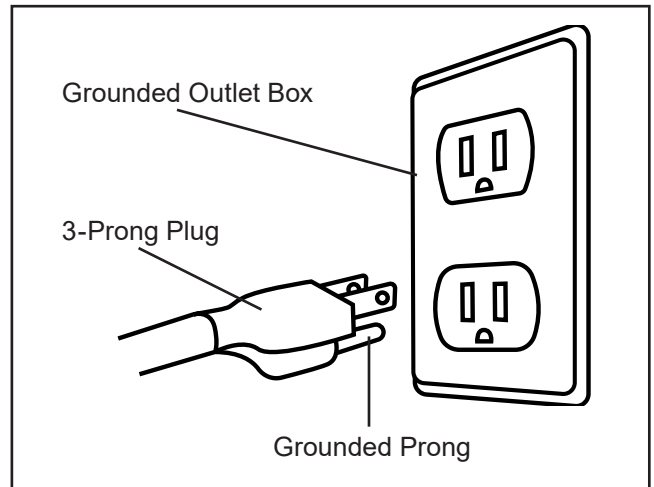

Do not permit fingers to touch the terminals of plug when installing or removing from outlet.

- Inspect tool cords periodically, and if damaged, have them repaired by an authorized service facility.
- The conductor with insulation having an outer surface that is green with or without yellow stripes is the equipment-grounding conductor. If repair or replacement of the electric cord or plug is necessary, do not connect the green (or green and yellow) wire to a live terminal.
- A temporary 3-prong to 2-prong grounding adapter (see Figure 6) may be used to connect this plug to a matching 2-conductor receptacle as shown in figure 6.
- The temporary adapter should be used only until a properly grounded outlet can be installed by a qualified electrician.

Figure 6

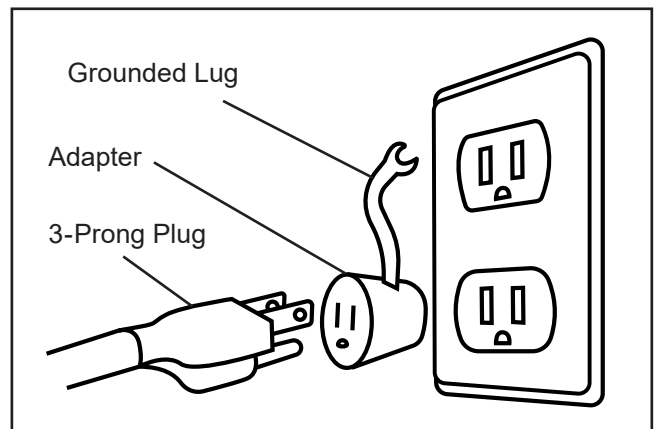

In Canada, the use of a temporary adapter is not permitted by the Canadian Electric Code. Where permitted, the rigid green tab or terminal on the side of the adapter must be securely connected to a permanent electrical ground such as a properly grounded water pipe, a properly grounded outlet box, or a properly grounded wire system.

- Many cover plate screws water pipes and outlet boxes are not properly grounded. To ensure proper grounding means that it must be tested by a qualified electrician.

EXTENSION CORDS

Use proper extension cords. Make sure the extension cord is in good condition. Use only 3-wire extension cords that have 3-prong grounding-type plugs and 3-pole receptacles which accept the tool plug. When using an extension cord, make sure to use one heavy enough to carry the current of the machine. An undersized cord will cause a drop in the voltage, resulting in loss of power and overheating. Use the table to determine the minimum wire size (A.W.G.) extension cord.

Extension Cord Length

Wire Size - A.W.G.

Up to 25ft - 16 guage

NOTE: Using extension cords over 25ft long is not recommended.

OPERATION

Refer to Figure 7 to 8

This air scrubber system can be controlled using the remote control (Figure 7) or the control panel (Figure 8) located at the rear of the unit.

NOTE: The filtration timing can ONLY be controlled with the remote.

ON/SPEED CONTROL

Press the ON/SPEED button on the remote control or the control panel. When turned on the air filtration system will be in the LOW speed. The LOW LED light on the control panel will illuminate. Press the ON/SPEED button to change speeds. The LOW, MID or HI LED light will illuminate to indicate the selected speed.

FILTRATION TIMING

NOTE: The filtration timing can ONLY be controlled with the remote.

The TIME button controls the timer setting. The 1 HR, 2 HR and 4HR LED lights on the control panel (Figure 8) will illuminate to show the filtration timing length.

- Press the TIME button once and the 1HR LED light will illuminate. The machine will operate for 1 hour then turn off.
- Press the TIME button twice and the 2HR LED light will illuminate. The machine will operate for 2 hours then turn off.
- Press the TIME button three times and the 4HR LED light will illuminate. The machine will operate for 4 hours then turn off.

NOTE: The filtration timing can ONLY be controlled with the remote.

TO TURN THE UNIT OFF

Press the OFF button on the remote control or the control panel to turn the unit off.

Figure 7

Remote Control

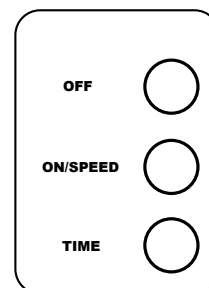
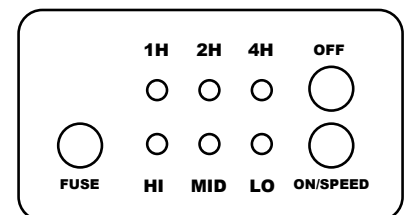

Figure 8

Control Panel



MAINTENANCE

WARNING

Disconnect the machine from power source whenever adjusting or replacing any parts.

CHANGING THE FILTERS

Refer to Figure 9

The inner and outer filters should be replaced and/or cleaned depending on the amount of usage and the environment of your workshop. Clogged filters will reduce the amount of air circulation.

- Lift up on the clips located at the top and bottom of the cabinet and remove the outer filter.
- Pull the inner filter from the cabinet. The inner filter can be blown out with air or washed to extend its life. The filter should be completely dry before reinstalling into the unit.
- Insert the new or cleaned inner filter and then install the new outer filter. The arrow on the outer filter indicates the air flow direction, ensure the filter is positioned properly.

FUSE REPLACEMENT

The fuse/fuse cap is located on the rear of the unit in the control panel. Replace the fuse if needed.

- Turn the fuse cap counterclockwise with a Phillips head screwdriver. Pull the fuse cap and fuse away from the control panel.
- Insert a new fuse (UL250V2A) into the fuse cap and place the fuse cap into the control panel. Turn the fuse cap clockwise to secure into place.

REMOTE CONTROL BATTERY REPLACEMENT

- Remove the battery compartment cover on the remote control.
- Replace the batteries. Ensure the batteries are oriented as shown inside the battery compartment. Use AA batteries.
- Replace the battery compartment cover.

NOTE: When disposing batteries, think of the protection of the environment. Check with your local authorities for an environmentally safe way of battery disposal.

Figure 9

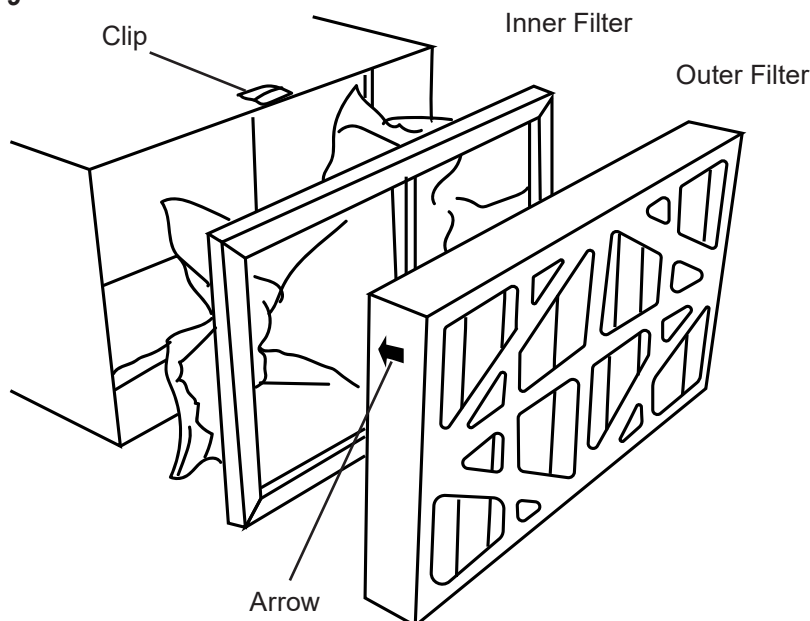

TROUBLESHOOTING

Symptom	Possible Cause	Corrective Action
Motor does not run.	<ol style="list-style-type: none"> 1. Machine not plugged in. 2. ON/SPEED button is in "OFF" position. 3. Power switch or cord is faulty. 4. Blown fuse or tripped circuit breaker. 5. Remote control is not working. 6. Remote control batteries are dead. 7. Infrared receiver is not working. 8. Control panel ON/OFF button is not working. 9. Control panel fuse is blown. 10. Motor does not work. 	<ol style="list-style-type: none"> 1. Plug power cord into electrical receptacle. 2. Press the ON/SPEED button to turn unit on. 3. Replace switch or power cord. 4. Overloaded electrical circuit. 5. Point remote control directly at control panel. <ul style="list-style-type: none"> • Make sure infrared remote sensor on the control panel is not blocked. • Move remote control closer to the control panel for better direct infrared signal. 6. Replace batteries. See Remote Control Battery Replacement for instructions. 7. Inspect or replace control panel circuit board. 8. Inspect or replace control panel circuit board. 9. Replace blown fuse, see Fuse Replacement for instructions. 10. Replace motor.
Motor stalls or does not have full power.	<ol style="list-style-type: none"> 1. Incorrect line voltage. 2. Motor capacitor has failed. 3. Control panel circuit board has failed. 	<ol style="list-style-type: none"> 1. Have a qualified electrician check circuit for proper voltage. 2. Replace motor capacitor. 3. Inspect or replace control panel circuit board.
System has vibration or is noisy.	<ol style="list-style-type: none"> 1. Motor or cabinet part is loose. 2. Motor fan is rubbing cover. 3. Motor bearing are loud. 4. Air filters rattle. 5. Impellar fan is loose, unbalanced or damaged. 6. Motor base is loose in the cabinet. 	<ol style="list-style-type: none"> 1. Inspect all hardware and retighten or replace. 2. Check position of fan and cover. 3. Rotate motor shaft to isolate the issue. 4. Inspect and reposition filters. 5. Turn machine off and unplug from power <ul style="list-style-type: none"> • Inspect impellar for bent or damaged areas. • Secure impellar on motor shaft or replace. 6. Tighten any loose fasteners.
Poor air flow and dust collection.	<ol style="list-style-type: none"> 1. Filters are dirty. 2. Poor system location in shop. 	<ol style="list-style-type: none"> 1. Clean or replace both air filters frequently. 2. Reposition system in the shop for best air circulation.

AIR SCRUBBER SYSTEM PARTS LIST

Key No.	Part No.	Description	Qty.	Key No.	Part No.	Description	Qty.
1	AF4000001	Hex Nut	13	38	AF4000038	Pan Head Screw	1
2	AF4000002	Flatwasher	13	39	AF4000039	Fuse Holder	1
3	AF4000003	Lock Washer	13	40	AF4000040	Fuse Holder Cap	1
4	AF4000004	Pan Head Screw	5	41	75013	Fuse	1
5	AF4000005	Pan Head Screw	6	42	AF4000042	Control Panel Label	1
6	AF4000006	Air Box Front Cover	1	43	AF4000041	Flat Head Screw	2
7	AF4000007	Grilde Plate	1	44	AF4000043	Self Tapping Screw	2
8	AF4000008	Air Guide	1	45	AF4000044	Printed Circuit Board	2
9	AF4000009	Hex Nut	6	46	AF4000045	Switch Box	1
10	AF4000010	Flat Washer	6	47	AF4000046	Flat Washer	4
11	AF4000011	Lock Washer	6	48	AF4000047	Lock Washer	4
12	AF4000012	Socket Head Cap Screw	8	49	AF4000048	Hex Nut	4
13	AF4000013	Self Tapping Screw	10	50	AF4000049	Wire	1
14	AF4000014	Air Box	1	51	AF4000050	Fan Wheel	1
15	AF4000015	Pan Head Screw	4	52	AF4000051	Fan Housing Cover - L	1
16	AF4000016	Handle	1	53	AF4000052	Fan Housing Cover - M	1
17	AF4000017	Handle Bracket	1	54	AF4000053	Rubber Spacer	4
18	AF4000018	Pan Head Screw	2	55	AF4000054	Large Washer	4
19	AF4000019	Flat Washer	3	56	AF4000055	Nylon Insert Lock Nut	4
20	AF4000020	Lock Washer	3	57	AF4000056		
21	AF4000021	Hex Nut	6	58	75010	Motor	1
22	AF4000022	Pan Head Screw	1	59	AF4000059	Capacitor Cover	1
23	AF4000023	Tooth Lock Washer	2	60	AF4000060	Capacitor	1
24	AF4000024	Wire	1	61	AF4000061	Fan Housing Cover - R	1
25	AF4000025	Grilde Plate	1	62	AF4000062	Hex Cap Screw	4
26	75006	Inner Pocket Filter	1	63	AF4000063	Eye Bolt	4
27	75007	Electrostatic Outer Filter	1	64	AF4000064	Flange Nut	4
28	AF4000028	Rubber Foot	4	65	AF4000065	Hook Chain	4
29	AF4000029	Remote Control Label	1	66	AF4000066	Wire Nut 18AWG	2
30	AF4000030	Remote Control Tap Cover	1	67	AF4000067	Stripe Label	2
31	AF4000031	Battery	2	68	AF4000068	Logo Label	2
32	AF4000032	Spring	1	69	AF4000069	Switch Box Cover	1
33	AF4000033	Remote Control Bottom Cover	1	70	AF4000070	Lock Wire Nut	2
34	AF4000034	Battery Cover	1	71	AF4000071	Lock Wiring Nut	1
35	AF4000035	Remote Control PCB	1	72	AF4000072	Hook Screw	4
36	AF4000036	Power Cord	1	73	AF4000073	Tooth Lock Washer	1
37	AF4000037	Strain Relief	1	74	AF4000074	Insulation Washer	2

WARRANTY

Thank you for investing in the AirSafti tool. These products have been made to demanding, high-quality standards and are guaranteed for domestic use against manufacturing faults for a period of 5 years from the date of purchase.

This guarantee does not affect your statutory rights. In case of any malfunction of your tool (failure, missing part, etc.), please contact one of our service technicians at our service line at (678) 971-4388 from 9 am to 5 pm, Monday to Friday, EST. BioCide Labs reserves the right to repair or replace the defective tool, at its discretion.

Normal wear and tear, including accessory wear, is not covered under this guarantee. The product is guaranteed for 5 years if used for normal trade purposes. Any guarantee is invalid if the product has been overloaded or subject to neglect, improper use, or an attempted repair other than by an authorized agent. Heavy-duty, daily professional or hire usage is not guaranteed. Due to continuous product improvement, we reserve the right to change the product specification without prior notice.

WHAT IS COVERED UNDER THE LIMITED FIVE-YEAR WARRANTY

This warranty covers all defects in workmanship for materials in this BioCide Labs tool for five years from the date of purchase. This warranty is specific to this tool.

HOW TO OBTAIN SERVICE

To obtain service for the tool you must return it, freight prepaid, to an authorized BioCide Labs service center. You may obtain the location of an authorized service center please call (678- 971-4388 when requesting warranty service, you must present proof of purchase, the authorized service center will repair any faulty workmanship, and either repair or replace any defective parts.

Makes no warranties, representations, or promises as to the quality or performance of its power tools other than those specifically stated in this warranty.

Additional Limitations

To the extent permitted by applicable law, all implied warranties, including warranties of MERCHANTABILITY or FITNESS OF PARTICULAR PURPOSE, are disclaimed. Any implied warranties, including warranties of merchantability or fitness for a purpose, that cannot be disclaimed under state law are limited to one year from the date of purchase. BioCide Labs is not responsible for the direct, indirect, incidental or consequential damages. Some states do not allow limitations on how long an implied warranty lasts and/or do not allow the exclusion or limitation of incidental or consequential damages, so the above limitations may not apply to you. This warranty gives you specific legal rights, and you may also have other rights which vary from state to state.

NOTES



NOTES

A large, empty rectangular box with a thin black border, intended for taking notes. It is connected to the 'NOTES' header by a horizontal line extending from the right side of the header box, and a vertical line extending downwards from the left side of the header box.



Air-Safti
AIR SCRUBBER



(678) 971-4388

www.biocidelabs.com